

Programme Book

# The 1<sup>st</sup> International Conference on Accident Prevention

October 20 ~22, 2010  
Westin Chosun Hotel, Busan, Korea



## Organized by

-  Korea Occupational Safety and Health Agency
-  The Korean Society of Safety

## Supported by

-  Ministry of Employment and Labor
-  International Commission on Occupational Health  
Scientific Committee on Accident Prevention

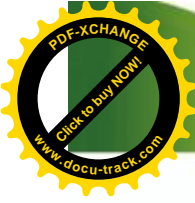

# SEOUL DECLARATION

## on Safety and Health at Work

1. Promoting high levels of safety and health at work is the responsibility of society as a whole and all members of society must contribute to achieving this goal by ensuring that priority is given to occupational safety and health in national agendas and by building and maintaining a national preventative safety and health culture.
2. A national preventative safety and health culture is one in which the right to a safe and healthy working environment is respected at all levels, where governments, employers and workers actively participate in securing a safe and healthy working environment through a system of defined rights, responsibilities and duties, and where the principle of prevention is accorded the highest priority.
3. The continuous improvement of occupational safety and health should be promoted by a systems approach to the management of occupational safety and health, including the development of a national policy taking into consideration the principles in Part II of the ILO Occupational Safety and Health Convention, 1981 (No. 155).
4. Governments should
  - Consider the ratification of the ILO Promotional Framework for Occupational Safety and Health Convention, 2006 (No. 187) as a priority, as well as other relevant ILO Conventions on safety and health at work and ensure the implementation of their provisions, as a means to improve national performance on safety and health at work in a systematic way.
  - Ensure that continued actions are taken to create and enhance a national preventative safety and health culture.
  - Ensure that the occupational safety and health of workers is protected through an adequate and appropriate system of enforcement of safety and health standards, including a strong and effective labour inspection system.
5. Employers should ensure that
  - Prevention is an integral part of their activities, as high safety and health standards at work go hand and hand with good business performance.
  - Occupational safety and health management systems are established in an effective way to improve workplace safety and health.
  - Workers and their representatives are consulted, trained, informed and involved in all measures related to their safety and health at work.
6. Affirming the workers' right to a safe and healthy working environment, workers should be consulted on safety and health matters and should:
  - Follow safety and health instructions and procedures, including on the use of personal protective equipment.
  - Participate in safety and health training and awareness-raising activities.
  - Cooperate with their employer in measures related to their safety and health at work.
7. The World Congress on Safety and Health at Work is an ideal forum to share knowledge and experiences in achieving safe, healthy and productive workplaces.
8. Progress made on achieving safety and health at work should be reviewed on the occasion of the XIX World Congress on Safety and Health at Work in 2011.
9. The Summit participants commit to taking the lead in promoting a preventative safety and health culture, placing occupational safety and health high on national agendas.



# The 1st International Conference on Accident Prevention

## - Accident Prevention through the Implementation of the Seoul Declaration on Safety and Health at Work



## Contents

---

02	Welcome Message President of KOSHA President of KOSOS Chairman of ICOH-SCAP
05	Conference Overview
05	Organizing Committee
06	Timetable
07	Programme
10	Technical Session
15	Poster Session
18	Technical Visit
18	Busan City tour
19	Floor Plan
20	Local Information
21	Sponsors

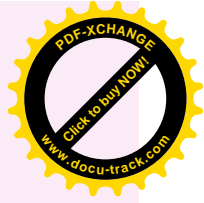

**Min-Ki Noh**  
President  
Korea Occupational Safety  
and Health Agency

I am truly delighted to be here in Busan on the occasion of the 1st International Conference on Accident Prevention.

My warm welcome goes to distinguished speakers and participants from home and abroad for attending the ICAP 2010 Conference. In addition, I thank President Jae-Yeong Park of the Korean Society of Safety and Chairman Keith Scott of the ICOH-Scientific Committee on Accident Prevention for their efforts in the preparation for the conference.

As many of you know, the 31st ICOH Congress is to be held in Seoul, Korea in 2015. KOSHA is making the necessary preparations to make the ICOH Congress in 2015 a venue for the exchange of information and a variety of festivals, with the participation of global occupational safety and health experts.

Against this backdrop, the ICAP 2010 is a good starting point for KOSHA to prepare for the successful hosting of ICOH Congress in 2015. The ICAP 2010 is co-hosted by the Korean Society of Safety, as an organization sharing the same mind as KOSHA. Furthermore, the ICAP 2010 is the first international conference to be supported by the Scientific Committee on Accident Prevention of ICOH.

The ICAP 2010 continues for three days with the theme of Accident Prevention through the Implementation of the Seoul Declaration on Safety and Health at Work. There will be keynote speeches and special lectures from 10 renowned OSH experts around the world, oral presentations on 13 topics and subjects, poster sessions, ICOH-SCAP general meeting, technical tours and so on. I ask for your continued interest and participation throughout the conference schedule.

I hope the ICAP 2010 will be a good chance for us to upgrade the global safety and health level by creating a common ground on safety and health and strengthening the network for information exchanges. Once again, I thank all the distinguished guests for attending. I wish for the best of safety and health of workers around the world.

Thank you.

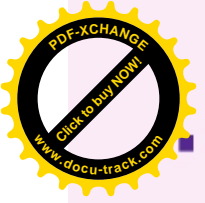

## ■ ■ The 1st International Conference on Accident Prevention



**Jae-Yeong Park**

President  
The Korean Society of Safety (KOSOS)

Autumn is the season of abundance and rich harvest. I wish all of you and your family the best of happiness.

Busan is a blessed city with its beautiful natural environment and a variety of international festivals throughout the year. It is the center of culture, movies and tourism, as well as the logistics hub of northeast Asia.

The Korean Society of Safety (KOSOS) is delighted have the 1st International Conference on Accident Prevention (ICAP 2010) right here in Busan. The KOSOS, Korea Occupational Safety and Health Agency (KOSHA) and the Scientific Committee on Accident Prevention of the International Commission on Occupational Health (ICOH-SCAP) have been working together for this conference, and the theme of the ICAP 2010 is Accident Prevention through the Implementation of the Seoul Declaration on Safety and Health at Work.

The ICAP 2010 seeks to contribute to accident prevention activities in workplaces by finding excellent papers from around the world. The key areas of focus during the ICAP 2010 conference are: prevention projects on three most frequent accidents, which are the focus of occupational accident management and prevention activities; and risk management. In addition to 120 excellent papers from countries around the world including the UK, Japan, Australia, Taiwan, etc., there will be keynote speeches by many notable speakers including Dr. Kazutaka Kogi from ICOH, Mr. Keith Scott from ICOH-SCAP, and Dr. Yutaka Maeda from JNIOH.

The ICAP 2010 will certainly be the opportune occasion for all participants to share the knowledge and experiences on occupational accident prevention activities.

In addition, I am sure that many scholars and experts from around the world will have very good chance to share ideas on safety and health field, while building friendship for future cooperation. I ask all of you to actively participate throughout the conference.

In closing, I extend my sincere appreciation toward all participants, speakers, and the organizing staff for their contribution and hard work.

Thank you.



WELCOME

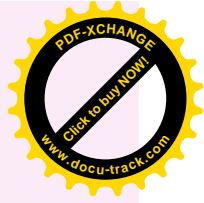

**Keith Scott**

Chairman  
ICOH-Scientific Committee on Accident  
Prevention  
Chairman of IIRSM  
(International Institute of Risk and  
Safety Management)

As Chairman of the ICOH Accident Prevention Committee and its Scientific Committee on Accident Prevention, it is my very great pleasure to welcome you all to this International Conference on Accident Prevention here in Busan. It is one of my strongly held beliefs that safety knows no boundaries and to see so many people from such a wide range of countries encourages me immensely.

The saving of life and prevention of ill-health & injury are of key importance to us all. Not only is there a shameful waste of life together with unnecessary pain and suffering to families and others, but the loss to society has been estimated by the International Labour Organisation and World Health Organisation, but cost trillions of dollars.

In the course of this conference we will be hearing speakers from around the globe addressing issues of key importance to us all. These speakers will be sharing with us the benefits of their research and practical experience which hopefully, we can take home with us for the benefit of all.

This global perspective was encapsulated in the Seoul Declaration on Safety & Health at Work, which was signed by forty six representatives from around the world on June 29th, 2008 at the 18th World Safety Congress held here in South Korea. Much progress has been made toward achieving the aims of the Declaration but much still remains to be done. This will require efforts from governments, businesses, NGOs, trade unions and all other stakeholders and I hope that at the end of this Conference you will return home even more committed and with new ideas for action.

While you are here, I hope that you will take the unique opportunity for networking which this conference presents. Communication between interested parties is key to achieving our objectives. No single person has the monopoly on good solutions so these must be shared.

Finally I would like to thank the Korean Occupational Safety & Health Agency and Korean Society of Safety for all their efforts in organising what I am sure it will be a fascinating and enjoyable conference. I would also like to thank the Japan Society for Safety Engineering for its efforts. Please have a fruitful conference.

Thank you.

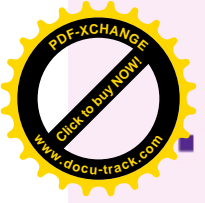

# ■ ■ The 1st International Conference on Accident Prevention

## Accident Prevention through the Implementation of the Seoul Declaration on Safety and Health at Work

Date : October 20~22, 2010

Venue : Westin Chosun Hotel, Busan, Korea

Organized by : Korea Occupational Safety and Health Agency(KOSHA)  
The Korean Society of Safety(KOSOS)

Supported by : Ministry of Employment and Labor(MOEL)  
Scientific Committee on Accident Prevention  
International Commission on Occupational Health(ICOH-SCAP)

### ❁ International Advisory Committee

Chair Keith SCOTT (International Institute of Risk and Safety Management, UK)  
Vice-Chair Dae-Yul CHOI (KOSHA, Korea)  
Chang-Sub SHIN (Chungbuk National University, Korea)  
Terushige OGAWA (Yokohama National University, Japan)

### ❁ Organizing Committee

Co-Chair Min-Ki NOH (KOSHA, Korea)  
Jae-Yeong PARK (KOSOS, Korea)  
Vice-Chair Seong-Kyu KANG (KOSHA, Korea)  
Jae-Hee CHUNG (KOSOS, Korea)  
Members Joon-Won LEE (KOSHA, Korea)  
Chung-Ho LEE (KOSHA, Korea)  
Jung-Sun PARK (KOSHA, Korea)  
Young-Duck KIM (KOSHA, Korea)  
Keun-Oh LEE (Seoul National University of Science & Technology, Korea)  
Boo-Hyung RYU (Dongguk University, Korea)  
Gi-Heung CHOI (Hansung University, Korea)  
Secretary Jin-Young KWON (KOSHA, Korea)

### ❁ Programme Committee

Chair Jai-Hak PARK (Chungbuk National University, Korea)  
Members Hyuck-Myun KWON (KOSHA, Korea)  
Sung-Hoon JUNG (KOSHA, Korea)  
Keun-Won LEE (KOSHA, Korea)  
Jae-Kun YOON (Hansung University, Korea)  
Dong-Myeong HA (Semyeong University, Korea)  
Soo-Beom LEE (University of Seoul, Korea)  
Seong-Rok CHANG (Pukyong National University, Korea)

### ❁ Secretariat

Director Joon-Won LEE (KOSHA, Korea)  
Members Nam-Kyu PARK (KOSHA, Korea)  
Hyung-Hwan AN (Chungju National University, Korea)  
Se-Wook SONG (KOSHA, Korea)  
Kyo-Sik KIM (KOSHA, Korea)  
Woon-Chul SHIN (KOSHA, Korea)  
Secretary Jin-Young KWON (KOSHA, Korea)  
Jong-Kyu KWON (KOSHA, Korea)  
Hyung-Seok KIM (KOSHA, Korea)  
Eun-Ju LEE (KOSOS, Korea)

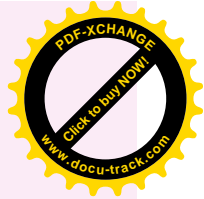

TIME TABLE



## ICAP 2010 Programme

### Wednesday, October 20, 2010

Time	Room	A : Rose + Lilac	B : Tulip + Cosmos	C : Violet
08:00 - 18:00	Registration : The Westin Chosun Hotel Busan Poster session (Grand Ballroom B) (12:00~18:00)			
10:00 - 12:00	ICOH-SCAP General Meeting (Violet, 2nd floor)			
12:00 - 13:30	Luncheon (Orchid, 2nd floor)			
13:30 - 14:00	Opening Ceremony (Grand Ballroom A)			
14:00 - 15:40	Keynote speeches (Grand Ballroom A)			
15:40 - 16:00	Coffee Break			
16:00 - 17:40	Technical Sessions 1-3			
	Session 1 - WA4 Seoul Declaration on Safety and Health at Work	Session 2 - WB4 Occupational accident analysis and statistics	Session 3 - WC4 Agricultural safety and health	
	Poster session (Grand Ballroom B) *Discussion with Authors			
17:40 - 18:10	Poster session (Grand Ballroom B) *Discussion with Authors			
18:30 - 20:00	Welcome Reception (Grand Ballroom A)			

### Thursday, October 21, 2010

Time	Room	A : Rose + Lilac	B : Tulip + Cosmos	C : Violet
08:00 - 18:00	Registration : The Westin Chosun Hotel Busan Poster session (Grand Ballroom B)			
09:00 - 10:40	Technical Sessions 4-6			
	Session 4 - TA1 Accident prevention policies & safety culture	Session 5 - TB1 Risk assessment and management I	Session 6 - TC1 Accident prevention involving machineries	
	Coffee Break			
10:50 - 12:30	Technical Sessions 7-9			
	Session 7 - TA2 Ergonomics and systems safety	Session 8 - TB2 Risk assessment and management II	Session 9 - TC2 Construction accident prevention	
	Luncheon (Grand Ballroom A) *We offer luncheon			
13:30 - 15:10	Technical Sessions 10-12			
	Session 10 - TA3 Trips, falls and crush accidents prevention	Session 11 - TB3 Fire and explosion accident prevention I	Session 12 - TC3 Traffic accident prevention	
	Coffee Break			
15:30 - 17:10	Technical Sessions 13-15			
	Session 13 - TA4 Safety and health management system	Session 14 - TB4 Fire and explosion accident prevention II	Session 15 - TC4 Accident prevention involving electricity	
	Break Time			
17:10 - 19:00	Gala Dinner (Grand Ballroom A)			
19:00 - 21:00	Gala Dinner (Grand Ballroom A)			

### Friday, October 22, 2010

Time	Room	A : Rose + Lilac	B : Tulip + Cosmos	C : Violet	
09:00 - 12:00	Registration : The Westin Chosun Hotel Busan Poster session (Grand Ballroom B)				
09:00 - 10:40	Special Lectures (Grand Ballroom A)				
10:40 - 11:00	Coffee Break				
11:00 - 12:00	Closing Ceremony (Grand Ballroom A)				
12:00 - 13:30	Luncheon (Rose/Lilac/Tulip/Cosmos) * We offer luncheon				
13:30 - 18:00	Technical Visits / Busan City Tour				
	Technical Visit 1 Hyundai Heavy Industries	Technical Visit 2 Hyundai Motor Company	Technical Visit 3 KORI Nuclear Power Plants	Technical Visit 4 SK Energy	City Tour Busan City Tour

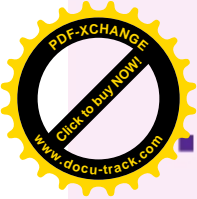

# The 1st International Conference on Accident Prevention

OGGRAMM

October 20 (Wed), 2010							
08.00-18.00	Registration : The Westin Chosun Hotel Busan Poster Session : Grand Ballroom B						
10:00-12:00 Room Violet	General Meeting of ICOH-SCAP (open for all)						
12:00-13.30 Orchid	Luncheon						
13:30-14.00 Grand Ballroom A	<p><b>Opening Ceremony</b></p> <p>Welcome &amp; Congratulatory Remarks</p> <p>Min Ki NOH, President, Korea Occupational Safety and Health Agency (KOSHA)</p> <p>Jae Yeong PARK, President, The Korean Society of Safety (KOSOS)</p> <p>Yoon Vae KIM, Director General of Occupational Safety and Health Bureau, Ministry of Employment and Labor</p> <p>Terushige OGAWA, President, Asia Pacific Association of Safety Engineering Societies (APASES)</p> <p>Keith SCOTT, Chairman, ICOH-SCAP (Scientific Committee on Accident Prevention)</p>						
14:00-15.40 Grand Ballroom A	<p><b>Keynote Speeches</b></p> <p>Min Ki NOH, President, Korea Occupational Safety and Health Agency (KOSHA)</p> <p>: Accomplishments and challenges of Korea's Occupational Safety and Health</p> <p>Kazutaka KOGI, President of ICOH (International Commission on Occupational Health)</p> <p>: Practical hints from work improvement initiatives for promotion of accident prevention.</p> <p>Jae Yul LEE, Director General, Disaster &amp; Safety Control Bureau, Ministry of Public Administration and Security</p> <p>: Policy directions of disaster and safety management</p> <p>Keith SCOTT, Chairman, ICOH-SCAP</p> <p>: Risk Assessment in Europe</p> <p>Yutaka MAEDA, President, National Institute of Occupational Safety and Health, Japan (JNIOSH)</p> <p>: Research Strategy on Industrial Safety in Japan</p>						
15.40-16.00	Coffee Break						
16.00-17.40 Room Rose-Violet	<p><b>Technical Sessions (1-3)</b></p> <table border="1"> <thead> <tr> <th>Session WA4</th> <th>Session WB4</th> <th>Session WC4</th> </tr> </thead> <tbody> <tr> <td>Seoul Declaration on Safety and Health at Work Chair : Joon Won LEE, Jae Ho JEON</td> <td>Occupational accident analysis and statistics Chair : Kyung Yong RHEE, Yasushi OKUBO</td> <td>Agricultural safety and health Chair : Kwang Suk LEE, Kyung Suk LEE</td> </tr> </tbody> </table>	Session WA4	Session WB4	Session WC4	Seoul Declaration on Safety and Health at Work Chair : Joon Won LEE, Jae Ho JEON	Occupational accident analysis and statistics Chair : Kyung Yong RHEE, Yasushi OKUBO	Agricultural safety and health Chair : Kwang Suk LEE, Kyung Suk LEE
	Session WA4	Session WB4	Session WC4				
Seoul Declaration on Safety and Health at Work Chair : Joon Won LEE, Jae Ho JEON	Occupational accident analysis and statistics Chair : Kyung Yong RHEE, Yasushi OKUBO	Agricultural safety and health Chair : Kwang Suk LEE, Kyung Suk LEE					
17.40-18.10 Grand Ballroom B	Poster Session (Discussion with authors)						
18.30-20.00 Grand Ballroom A	Welcome Reception						

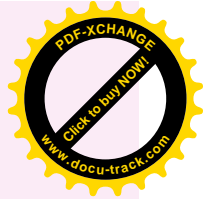

PROGRAMME



**October 21 (Thu), 2010**

08.00-18.00	Registration : The Westin Chosun Hotel Busan Poster Session : Grand Ballroom B		
09.00-10.40 Room Rose~Violet	<b>Technical Sessions (4-6)</b>		
	Session TA1 Accident prevention policies & safety culture Chair : Chan O KIM, Robin NICHOLAS	Session TB1 Risk assessment and management I Chair : Dal Jae PARK, Ngoc Minh LY	Session TC1 Accident prevention involving machineries Chair : Tae Gu KIM, Sung Ho LEE
10.40-10.50	Coffee Break		
10.50-12.30 Room Rose~Violet	<b>Technical Sessions (7-9)</b>		
	Session TA2 Ergonomics and systems safety Chair : Seong Rok CHANG, Hyeon Kyo LIM	Session TB2 Risk assessment and anagement II Chair : Mee Jin KANG, Takeshi HIMOTO	Session TC2 Construction accident prevention Chair : Shin Won PAIK, Promila SHARMA
12.30-13.30 Grand Ballroom A	Luncheon *(we offer luncheon)		
13.30-15.10 Room Rose~Violet	<b>Technical Sessions (10-12)</b>		
	Session TA3 Trips, falls and crush accidents prevention Chair : Young Guk KWON, Young Duk KIM	Session TB3 Fire and explosion accident prevention I Chair : Hyuk Myun KWON, James M. DEWEY	Session TC3 Traffic Accident prevention Chair : Soo Beom LEE, Jun Seok LEE
15.10-15.30	Coffee Break		
15.30-17.10 Room Rose~Violet	<b>Technical Sessions (13-15)</b>		
	Session TA4 Safety and health managementsystem Chair : Michael STEPHENS, Byoung Nam CHOI	Session TB4 Fire and explosion accident prevention II Chair : Il MOON, Steven C. DEVEREAUX	Session TC4 Accident prevention involving electricity Chair : Doo Hyun KIM, Bo Hyuk RYU
17.10-19.00	Coffee Break		
19:00-21:00 Grand Ballroom A	Gala Dinner		

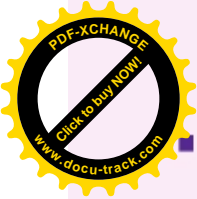

# The 1st International Conference on Accident Prevention

OGRAMM

October 22 (Fri), 2010					
09.00-12.00	Registration : The Westin Chosun Hotel Busan Poster Session: Grand Ballroom B				
09.00-10.40 Grand Ballroom A	<p><b>Special Lectures</b></p> <p>Seong Kyu KANG, Director General, OSHRI-KOSHA : Understanding the Occupational Injury Statistics of Korea</p> <p>Hongwei HSIAO, Chief, Protective Technology Branch, NIOSH, : Occupational Injury Prevention Research in the US: Strategic Goals, Activities and Impacts</p> <p>Takehiro MATSUNAGA, Secretary, Asia Pacific Association of Safety Engineering Societies (APASES), Researcher of National Institute of Advanced Industrial Science and Technology : Introduction of Safety Research Institutes in Japan and Development of the International Cooperation System</p> <p>Doo Yong PARK, Professor, Hansung University : Regulation by Directives and Performance Based Regulation - Selection and Harmonization</p> <p>Su Wang, Board of Directors, IIRSM/ Secretary, ICOH-SCAP : Re-launch of Scientific Committee on Accident Prevention, Re-union of Health AND Safety - A case study</p>				
10.40-11.00	Coffee Break				
11.00-12.00 Grand Ballroom A	<p><b>Closing Ceremony</b> <b>Closing remarks and future action plans of ICOH-SCAP</b></p> <p>Epilogue of ICAP 2010 (Video)</p> <p>Joon Won LEE, KOSHA, Secretary General, Secretariat for the Seoul Declaration on Safety and Health at Work : ICAP 2010 Summary</p> <p>Awards Ceremony for Excellent Papers</p> <p>Closing Remarks by the President of KOSHA</p> <p>Kazutaka KOGI, President of ICOH 'Reflection on the ICAP2010'</p> <p>Keith SCOTT, Chairman of IIRSM, Chairman of ICOH-SCAP : Future Development Plans and Action Plans for ICOH-SCAP</p> <p>Jae Yeong PARK, Closing of the ICAP 2010 Conference</p>				
12.00-13.30 Room(Ro/Li/Tu/Co)	Luncheon *(we offer luncheon)				
13.30-18.00	<b>Technical Visit 1-4 or Busan City Tour</b>				
	Technical Visit 1	Technical Visit 2	Technical Visit 3	Technical Visit 4	City Tour
	Hyundai Heavy Industries (Shipbuilding)	Hyundai Motor Company (Car Manufacturing)	KORI Nuclear Power Plants (Nuclear Power Generation)	SK Energy (Energy)	Busan City Tour

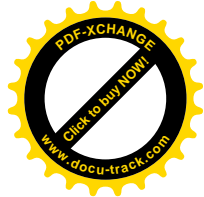
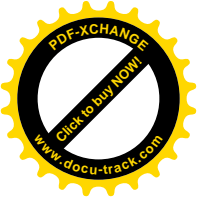

October 20 ~ 22, 2010  
The Westin Chosun Hotel, Busan, Korea

10



# The 1<sup>st</sup> International Conference on Accident Prevention

## Technical Session Wednesday, October 20

### Keynote Speeches (Grand Ballroom A, 1st Floor) Wednesday, October 20, 14:00 ~ 15:40

Chair: Doo Yong PARK (Hansung University, Korea)

#### WG3-1

#### Accomplishments and challenges of Korea's Occupational Safety and Health

Min Ki NOH, President, Korea Occupational Safety and Health Agency (KOSHA), Korea

#### WG3-2

#### Practical hints from work improvement initiatives for promotion of accident prevention

Kazutaka KOGI, President of ICOH (International Commission on Occupational Health), Japan

#### WG3-3

#### Policy directions of disaster and safety management

Jae Yul LEE, Director General, Disaster & Safety Control Bureau, Ministry of Public Administration and Security, Korea

#### WG3-4

#### Risk Assessment in Europe

Keith SCOTT, Chairman, ICOH-SCAP, UK

#### WG3-5

#### Research Strategy on Industrial Safety in Japan

Yutaka MAEDA, President, National Institute of Occupational Safety and Health (JNIOSH), Japan

### Special Session WA4 (Rose+Lilac, 2nd Floor) Wednesday, October 20, 16:00 ~ 17:40

#### Seoul Declaration on Safety and Health at Work

Chair: Joon Won LEE (KOSHA, Korea),  
Jae Ho JEON (Samsung Electronics, Korea)

#### WA4-1

#### Seoul Declaration on Safety and Health at Work : Promoting a Global Culture of Prevention

Joon Won LEE: KOSHA, Korea

#### WA4-2

#### Application of the PAOT Methodology and Seoul Declaration Session to Occupational Health Training Program in Korea

Myung Sook LEE, Byung Soo CHOI : Korean Industrial Health Association, Korea  
Kee Hong CHO: Federation of Korean Trade Unions, Korea  
Byung Kyu CHOI : Cheongju Regional Office of the Employment and Labor, Korea

#### WA4-3

#### Samsung Electronics' Health & Safety management

Jae Ho JEON : Samsung Electronics, Global Environment Safety & Health Group, Korea

#### WA4-4

#### A Case Study for the Improvement of Safety in Refining Industry

Chan Ho TAE : GS Caltex Health and Safety Planning Team, Korea  
Mee Hae LEE : GS Caltex and Safety Planning Team, Korea

### Technical Session WB4 (Tulip+Cosmos, 2nd Floor) Wednesday, October 20, 16:00 ~ 17:40

#### Occupational Accident Analysis and Statistics

Chair: Kyung Yong RHEE (KOSHA, Korea), Yasushi OKUBO (University of Tokyo, Japan)

#### WB4-1

#### Burden of Occupational Injuries in Mechanical Shipyard Building Workers

Nguyen Bich Diep, Nguten Khac Hai: National Institute of Occupational & Environmental Health, Vietnam

#### WB4-2

#### An Analysis of Accident Reports in a University

Yasushi OKUBO: Division for Environment, Health and Safety, University of Tokyo, Japan

#### WB4-3

#### Characteristics of Pollutant Emission on the Type of Interior Materials of Vehicles

In Bum KIM: Dept. of Safety Engineering, Graduate School, Seoul National University of Technology, Korea  
Young Seop YI: Dept. of Safety Engineering, Seoul National University of Technology, Korea  
Won Kyoung KO : Dept. of Safety Engineering, Graduate School of Energy and Environment, Seoul National University of Technology, Korea

#### WB4-4

#### Investigation and Validation of a Novel Text Mining Methodology for Accident Analysis

Wailok YIU, Derek R. SMITH, Lynette GUY : School of Health Sciences, Faculty of Health, University of Newcastle, Australia  
Benjamin Brooks : National Centre for Ports and Shipping, Australian Maritime College, University of Tasmania, Australia

#### WB4-5

#### General Assessment of Occupational Injuries in Korea From 2001 to 2008

Seong Weon CHOE, Kyung Yong RHEE : Safety and Health Statistics Team Occupational Safety and Health Research Institute, KOSHA, Korea

### Technical Session WC4 (Violet, 2nd Floor) Wednesday, October 20, 16:00 ~ 17:40

#### Agricultural Safety and Health

Chair: Kwang Suk LEE (Hongik University, Korea),  
Kyung Suk LEE (Rural Development Administration, Korea)

#### WC4-1

#### Paraquat Application and Respiratory Health Effects among South Korean Farmers

Eun Shil CHA, Eun Kyoung MOON, Won Jin LEE : Department of Preventive Medicine, College of Medicine, Korea University, Korea  
Yun Keun LEE : Wonjin Institute for Occupational and Environmental Health, Korea  
Yong Bae KIM, Yong Jin LEE : Department of Preventive Medicine, College of Medicine, Soonchunhyang University, Korea  
Woo Chul JEONG, Eun Young CHO, Ik Jin LEE, Jongil HUR : Taean Institute of Environmental Health, Korea  
Mina HA : Department of Preventive Medicine, Dankook University, Korea

#### WC4-2

#### Prevalence and Related Factors of the Acute Pesticide Intoxication Symptoms in Korean Farmers

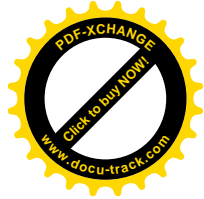
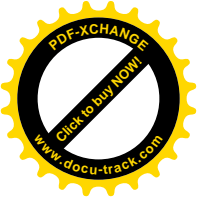

Soon Chan KWON, Soo Jin LEE : Department of Occupational and Environmental Medicine, Hanyang University, Korea  
Kyoung Sook LEE : Agricultural Safety Engineering Division, NAAS, RDA, Korea

**WC4-3**

**Carcinogenicity of Pesticides Used in Korea**

Sang Jun CHOI, Kyong Che LIM : Department of Occupational Health, Catholic University of Daegu, Korea  
Hyo Cheol KIM : National Academy of Agricultural Science, Rural Development Administration, Korea

**WC4-4**

**Effects of Biodegrade Pesticide Proof Clothing on Human Comfort**

Kyoung Sook HWANG, Kyung Suk LEE, Hyo Cher KIM, Hye Seon CHAE : Agricultural Safety Engineering Division, Rural Development Administration, Korea

**WC4-5**

**Safety Problems of Agricultural Equipments in an Ergonomics Prospective**

Kwan Suk LEE : Hongik University, Korea

**Technical Session TA1 (Rose+Lilac, 2nd Floor)  
Thursday, October 21, 9:00 ~ 10:40**

**Accident Prevention Policies and Safety Culture**

Chair: Chan-O KIM (Seoul National University of Science and Technology, Korea), Robin NICHOLAS (Health and Safety Communications, USA)

**TA1-1**

**Industrial Safety with Smart Phone**

Yu Mi OH : Korea Occupational Safety & Health Agency, Korea

**TA1-2**

**Accident Resulting in Disability, Vulnerable Groups and its Consequences**

Yun Suk PAK, Jin Wook BAHK, Do Myung PAEK : Department of Occupational and Environmental Medicine, School of public health and Institute of Health and Environment, Seoul National University, Korea

**TA1-3**

**Management, Community and Culture-creating an Environment of Well-being**

Robin NICHOLAS : Health and Safety Communications, USA

**TA1-4**

**A Proposal of a Supporting Method for Prevention of Human Errors in Hospitals**

Masanao ISHIHARA, Tatsuya FUKUDA, Yusaku OKADA : Faculty of Science and Technology, Keio University, Japan

**TA1-5**

**Risk Assessment by the Conscious Factors for Safety Culture**

Young Sig KANG : Department of Occupational Health & Safety Engineering, Semyung University, Korea  
Peom PARK : Department of Industrial & Information Systems Engineering, Ajou University, Korea  
Wonmo GAL : Department of Environmental Healthy and Safety, Eelji University, Korea  
Yong Gu YOON : SAMSUNG Electronics Co., Ltd. , Korea

**TA1-6**

**A Study on Improvement of Employees Satisfaction about Safety Activities in Medical Field**

Nihongi RYO, Naori TUJI : Science & Technology, Keio University, Japan

Masahiro TOMITA, Yusaku OKADA : Graduate School of Science & Technology, Keio University, Japan

**Technical Session  
Thursday, October 21**

**Technical Session TB1 (Tulip+Cosmos, 2nd Floor)  
Thursday, October 21, 9:00 ~ 10:40**

**Risk Assessment and Management I**

Chair: Dal Jae PARK (Seoul National University of Science and Technology, Korea), Ngoc Minh LY (Institute of Environmental Science, Engineering & Management, Vietnam)

**TB1-1**

**A Study on How to Encourage Companies to Comply with the New Regulation based on Risk Assessment in Korea**

Mee Jin KANG : Research Center for System Safety Attached to Seoul National University of Science and Technology, Korea  
Young Soon LEE : Department of Safety Engineering, Seoul National University of Science and Technology, Korea

**TB1-2**

**A Basic Study on Tower Crane Risk Assessment Method of Utilization**

Kyu Hyung SHIM : Korea Dangerous Machinery Inspection Association, Korea  
Jong In KIM : Korea Industrial Safety Association, Korea  
Dong Ho RIE : Department of Safety Engineering, University of Incheon, Korea

**TB1-3**

**Safety Evaluation on the LNG Vapor for the LNG Fuel Station**

Seung Hyun LEE : The Graduate School of Energy and Environment, Seoul National University of Science and Technology, Korea  
Young Soon LEE : Department of Safety Engineering, Seoul National University of Science and Technology, Korea  
Seung Kyu KANG, Seung Rim LEE : Institute of Gas Safety R&D, Korea Gas Safety Corporation, Korea

**TB1-4**

**Fire Hazard Analysis of a Steel Roof LNG Storage Tank**

Seung Rim LEE, Jong Gyu SUNG, Jeong Rock KWON : Institute of Gas Safety R&D, Korea Gas Safety Corporation, Korea  
Seung Hyun LEE, Young Soon LEE : The Graduate School of Energy and Environment, Seoul National University of Science and Technology, Korea

**TB1-5**

**Graded Safety Management for X-ray Irradiators**

Takeshi IIMOTO, Eriko HAYASHI, Keiji KIMURA : Environment, Health and Safety, The University of Tokyo, Japan  
Yuya KOIKE : Radioisotope Center, The University of Tokyo, Japan

**Technical Session TC1 (Violet, 2nd Floor)  
Thursday, October 21, 9:00 ~ 10:40**

**Accident Prevention Involving Machineries**

Chair: Tae Gu KIM (Inje University, Korea),  
Sung Ho LEE (KEPCO Research Institute, Korea)

**TC1-1**

**Effect of Inspection on the Failure Probability of Pipes**

Jai Hak PARK : Dept. of Safety Engineering, Chungbuk National University, Korea  
Young Hwan CHOI : Korea Institute of Nuclear Safety, Korea

**TC1-2**

**Safety Maintenance Program of Piping System in Domestic Nuclear Power Plants**



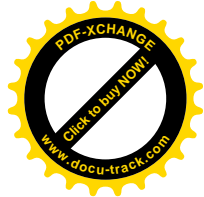
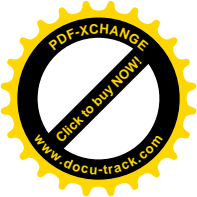

# The 1<sup>st</sup> International Conference on Accident Prevention

12

October 20 ~ 22, 2010  
The Westin Chosun Hotel, Busan, Korea



Sung Ho LEE : Nuclear Power Laboratory, KEPCO Research Institute, Korea

### TC1-3

#### A Study on the Stabilization of Electro-Pneumatic Braking Blending for using Regenerative Energy Storage System

Kyu Joong KIM : School of Energy & Environment, Seoul National University of Science and Technology, Korea  
Keun Oh LEE : Department of Safety Engineering, Seoul National University of Science and Technology, Korea  
Kil Dong KIM : Korea Railroad Research Institute, Korea  
Ju Yong KIM : Department of Railway Engineering, Woosong University, Korea  
Seoung Gil BAEK : Daejeon Metropolitan Express Transit Corporation, Korea

### TC1-4

#### A Comparative Analysis on the Tolerance and the Properties of Rupture Discs by using Finite Element Analysis

Hee Suk JUNG, Tae Gu KIM : Department of Safety Engineering, INJE University, Korea  
Ji Woong KANG : The Institute of Disaster and Accident Prevention, Pukyong National University, Korea

### Technical Session TA2 (Rose+Lilac, 2nd Floor) Thursday, October 21, 10:50 ~ 12:30

#### Ergonomics and Systems Safety

Chair: Seong Rok CHANG (Pukyong National University, Korea),  
Hyeon Kyo LIM (Chungbuk National University, Korea)

### TA2-1

#### Intra-subject Variation in Transmissibility of Seated Human Exposed to Vertical Vibration

Min Soo PARK, Takuya YOSHIMURA, Gen TMAOKI : Department of Mechanical Engineering, Tokyo Metropolitan University, JAPAN  
Tae Gu KIM : Department of Occupational Health & Safety Engineering Inje University, Korea

### TA2-2

#### Factors Associated with Musculoskeletal Symptoms of Workers in Frozen Seafood Processing Industry

Adulatch SAILABAHT : Faculty of Science, Ubon Ratchathani University, Thailand  
Natsuda PHUPHONGPHACHAROEN : Siam Woodland Co., Ltd., Thailand

### TA2-3

#### Characteristics of Work-related Musculoskeletal Disorders Cases in Korea

Hyun Ho KIM, Chan Young YOO, Duck Yeon CHO, Jeung Ho KIM, Jung Sun PARK : Occupational Health Department, KOSHA, Korea

### TA2-4

#### Applying BBS(Behavior Based Safety) in South Korea: Relative Effects of Global Feedback and Specific Feedback on Safety Behaviors

Kye Hoon LEE, She Zeen OAH : Department of Psychology, Chung-Ang University, Korea

### TA2-5

#### Perception Characteristics of Effective Safety Signs

Seung Won HWANG, Hyeon Kyo LIM : Dept. of Safety Eng., Chungbuk National University, Korea

### TA2-6

#### A Study on Cognitive Engineering Assessment and Analysis of Safety Signs Used in the Workplace

Byung Hyo KIM : Department of Occupational Health and Safety Engineering, Inje University, Korea

Sang Hyun LEE : Chang-Won Branch of Korea Industrial Safety Association, Korea

Soo Jin PARK : College of Design Visual Information Design, Inje University, Korea

Young Sig KANG : Department of Occupational Health and Safety Engineering, Semyung University, Korea

Tae Gu KIM : Department of Occupational Health and Safety Engineering, Inje University, Korea

### TA2-7

#### A Proposal for the Safe Weight in Lifting Works using a Psychophysical Method

Hyun Jin PARK : Safety & Health Policy Division, Ministry of Employment & Labor, Korea

Seong Rok CHANG : Division of Safety Engineering, Pukyong National University, Korea

### Technical Session TB2 (Tulip+Cosmos, 2nd Floor) Thursday, October 21, 10:50 ~ 12:30

#### Risk Assessment and Management II

Chair: Mee Jin KANG (Seoul National University of Science and Technology, Korea), Takeshi IIMOTO (University of Tokyo, Japan)

### TB2-1

#### Study and Apply the Pasquill-Gifford Puff Model to Calculate the Dispersion of the Hazard Substance in the Air for Assessing the Environmental Risk Caused by the Receiver of the Liquefied Petroleum Gas (LPG)

Ngoc Minh LY : Institute of Environmental Science, Engineering & Management (IESEM), Vietnam

### TB2-2

#### Theory and Practice of Risk Assessment in Korea

Hyuck Myun KWON : Korea Occupational Safety and Health Agency, Korea

Il MOON : Yonsei University, Korea

Doo Yong PARK : Hansung University, Korea

Young Soon LEE : Seoul National University of Technology, Korea

### TB2-3

#### Novel Training for Occupational Safety

Nachum TIR : Manager of Development & Projects Implementation, Israel Institute for Occupational Safety and Hygiene, Israel

Sigal SHAHAPURKER : Israel Institute for Occupational Safety and Hygiene, Israel

### TB2-4

#### Current Status and Strategy for 2011-2015 for Occupational Safety and Health in Vietnam

Anh Tho NGUYEN : Bureau for Safe Work, Ministry of Labour, Invalid and Social Affairs, Vietnam

Doo Yong PARK : Department of Mechanical Systems Engineering, Hansung University, Korea

### TB2-5

#### Road Accident Trends and Road Safety Policies in Korea

Jae Hoon SUL : Road Transport and Safety Department, Korea Transport Institute, Korea

### Technical Session TC2 (Violet, 2nd Floor) Thursday, October 21, 10:50 ~ 12:30

#### Construction Accident Prevention

Chair: Shin Won PAIK (Hankyong National University, Korea),  
Promila SHARMA (G.B.Pant Agricultural University, India)

**TC2-1**

**Safety Evaluation of Concrete Gravity Dams Considering Dynamic Fluid Pressure**

Yon Gon KIM, Shin Won PAIK : Department of Safety Engineering, Hankyong National University, Korea  
 Se Jong LIM : Safety & Health Policy Division, Ministry of Employment and Labor, Korea

**TC2-2**

**A Study on the Assessment for Ventilation Method to Improve the Working Environment of Tunnel Excavation**

Baek Yeol CHOI, In Ku LEE : University of Incheon graduate School, Korea  
 Dong Ho RIE : University of Incheon, Korea

**TC2-3**

**Safe Zone: Use PPE in Construction Industry Guide for Safety Managers**

Pratibha JOSHI, Promila SHARMA : Department of Family Resource Management, College of Home Science, G.B.Pant Univ. of Agri. & Tech., India

**TC2-4**

**Disasters Characteristics by Apartment Building Construction**

Jong Hyun PARK : Department of Architectural Engineering, University of Incheon, Korea  
 Don Heung CHOI : Korea Occupational Safety & Health Agency, Korea  
 Chan Sik LEE : Department of Architectural Engineering, University of Incheon, Korea

**TC2-5**

**Increase of Fatigue Strength in Welded Joints According to Post-Processing**

Sung Wook HONG : Dept. of Civil Engineering, Hallym College, Korea  
 Won Kyu CHAI : Dept. of Civil Engineering, ShinGu University, Korea  
 Myeong Gu LEE : Health & Safety Engineering Major, EuJi University, Korea

**Technical Session TA3 (Rose+Lilac, 2nd Floor)  
 Thursday, October 21, 13:30 ~ 15:10**

**Trips, Falls and Crush Accidents Prevention**

Chair: Young Guk KWON (Seoul National University of Technology, Korea), Young Duk KIM (KOSHA, Korea)

**TA3-1**

**Comparison of Tripping Probability between Male and Female according to obstacle height**

Kyoung Hun HAN, Jae Suk PARK : Department of Safety Engineering and Ergonomics Research, OSHRI, KOSHA, Korea

**TA3-2**

**A Comparison of Slip Resistance between the Grinded Outsoles and New Ones of Fire Fighter's Shoes**

Jung Soo KIM : Dept. Safety Eng. & Ergonomics Research, OSHRI, KOSHA, Korea  
 In Ju KIM : Department of Safety Research, NIOSH, USA  
 Chang Hoon BANG : Department Fire and Disaster Prevention Engineering, Kyungnam University, Korea

**TA3-3**

**Dynamic Performance Evaluation for a Guided Rail Type Falling Prevention System with a Bracket on the Wall**

Sang Tae KIM : Swelock asia CO.,LTD, Korea  
 Ji Woong KANG : The Institute of Disaster and Accident Prevention, Pukyong National University, Korea  
 Oh Heon KWON : Division of Safety Engineering, Pukyong National University, Korea

**TA3-4**

**Analysis of Toe and Heel Clearance during Stair Ascent and Descent**

Jae Suk PARK, Kyoung Hun HAN : Department of Safety Engineering & Ergonomics Research, Occupational Safety and Health Research Institute, KOSHA, Korea

**TA3-5**

**The Study of Strategies on Segmentation for Trip Accidents Prevention in Service Industry (Focus on Building Management Business)**

Jong Soon SA : Department for Accident Prevention in the Service Industry, KOSHA, Korea

**Technical Session TB3 (Tulip+Cosmos, 2nd Floor)  
 Thursday, October 21, 13:30 ~ 15:10**

**Fire and Explosion Accident Prevention I**

Chair: Hyuk Myun KWON (KOSHA, Korea),  
 James M. Dewey (Samsung Fire Insurance, Korea)

**TB3-1**

**Risk analysis and robustness evaluation of Renewable energy the case of dimethyl ether (DME)**

En Sup YOON, So WON : School of Chemical & Biological Engineering, Seoul Nation University, Korea

**TB3-2**

**Good Practices of Process Safety Leadership for Prevention of Major Accidents**

Hyung Sub Lee : Korea Occupational Safety & Health Agency, Korea

**TB3-3**

**Fire Protection Factors in Lithium Ion Battery Manufacturing**

Steven C. DEVEREAUX : Samsung Loss Control Center, Samsung Fire and Marine Insurance, Korea

**Technical Session TC3 (Violet, 2nd Floor)  
 Thursday, October 21, 13:30 ~ 15:10**

**Traffic Accident Prevention**

Chair: Soo Beom LEE (University of Seoul, Korea), Jun Seok LEE (Korea Institute of Construction Technology, Korea)

**TC3-1**

**Traffic Injury Severity Prediction by Algorithm based on Accident and Medical Record**

Soon Joo WANG : Hallym University, Korea  
 Hyung Yun CHOI : Hongik University, Korea

**TC3-2**

**The Effects of Prompting and Reinforcement on Safe Behavior of Bicycle and Motorcycle Riders on a Sidewalk**

Takeru OKINAKA : Graduate School of Humanities, Kwansei Gakuin University, Japan  
 Tsuneo SHIMAZAKI : School of Humanities, Kwansei Gakuin University, Japan

**TC3-3**

**Road Safety Evaluation using New Road Data Collection Analysis System and Road Accident Data**

Jun Seok LEE, Duk Geun YUN, Jung Gon SUNG: Korea Institute of Construction Technology, Korea

**TC3-4**

**Using the Principal Component Analysis for Modeling of the Pedestrian Accidents in Urban Areas**



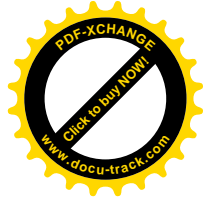
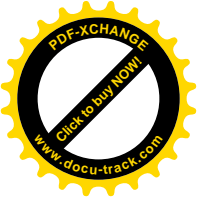

# The 1st International Conference on Accident Prevention

14

October 20 ~ 22, 2010  
The Westin Chosun Hotel, Busan, Korea

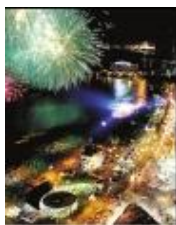

Yaser HATAMZADEH, Hasan JAVANSHIR : Islamic Azad University,  
South Tehran Branch, Faculty of Advanced studies, Iran  
Eraj BARGEGOL : University of Guilan, Faculty of Engineering, Iran

## TC3-5

### Speed Monitoring in Kuwait Oil Company (KOC) Fields

Al-Qattan FAHAD: Kuwait

## Technical Session TA4 (Rose+Lilac, 2nd Floor)

Thursday, October 21, 15:30 ~ 17:10

### Safety and Health Management System

Chair: Michael STEPHENS (Medical Research Council, UK),  
Byoung Nam CHOI (KOSHA, Korea)

## TA4-1

### Nationwide Survey of Disaster Drill based on Public Health Preparedness in Korea

Soon Joo WANG : Hallym University, Korea  
Jong Deuk HONG : Safekids Korea, Korea

## TA4-2

### Effectiveness and New Strategies of Occupational Safety and Health Management System (OSH-MS) in Korea

Byoung Nam CHOI: Korea Occupational Safety & Health Agency,  
Korea

## TA4-3

### Breaking Down Silos and Providing Inspiration for Good Health & Safety Management

Michael STEPHENS : Head of Health, Safety, Security and Business Continuity, Medical Research Council, UK

## TA4-4

### Development and Introduction of Quantitative Management Assessment(QMA) for Gas Facilities

Yung Ki YOON, Su Kyung LEE : Department of safety Engineering,  
Seoul National Univ. of Technology, Korea  
Jin Jun KIM, Che Sik KWAK : Technical Standards Division, Korea Gas Safety Corporation, Korea  
Seung Rim LEE : Institute of Gas Safety R&D, Korea Gas Safety Corporation, Korea

## TA4-5

### Control Strategy for Industrial Safety Based on Dynamic Modeling of Safety Budget-Industrial Accidents Relationship

Gi Heung CHOI : Department of Mechanical Systems Engineering,  
Hansung University, Korea

## TA4-6

### Evaluating the Effectiveness of Participatory Training for Occupational Injury Reduction: a Randomized Controlled Trial

Ignatius TS YU, Wenzhou YU, Xiaorong WANG, Shaohua Xie : School of Public Health and Primary Care, the Chinese University of Hong Kong, China  
Zhimin LI, Hui LIN : Shenzhen Hospital for Occupational Disease Control and Prevention, China  
Trevor SUN, Sabrina WAN, Karen LO : Hong Kong Workers' Health Centre, China

## Technical Session TB4 (Tulip+Cosmos, 2nd Floor)

Thursday, October 21, 15:30 ~ 17:10

### Fire and Explosion Accident Prevention II

Chair: Il MOON (Yonsei University, Korea), Steven C. DEVEREAUX  
(Samsung Loss Control Center, Korea)

## TB4-1

### Using Fire Prevention

James M. DEWEY : Samsung Loss Control Center, Korea

## TB4-2

### Risk Control of Internal Pressure Increase at Confined Zone Fire at Nuclear Power Plant

Moon Hak JEE : KEPCO Research Institute, Korea

## TB4-3

### The Study of Estimation Actual Fire Test Result and Evaluation Fire Hazard using a Cone Calorimeter

Sang Hoon RYU : FESTEC International Co., Ltd., Korea  
Sung Woong MOON, Ha Young KIM : University of Incheon Graduate School, Korea  
Kyung Bum LIM : Hyecheon University, Korea  
Dong Ho RIE : University of Incheon, Korea

## TB4-4

### Effectiveness of Implementing PSM and Organizing Special Body to Prevent Major Chemical Accidents

Hee Chul PARK, Hyuck Myun KWON, Dae Sik YIM : Korea Occupational Safety & Health Agency, Korea

## Technical Session TC4 (Violet, 2nd Floor)

Thursday, October 21, 15:30 ~ 17:10

### Accident Prevention Involving Electricity

Chair: Doo Hyun KIM (Chungbuk National University, Korea),  
Bo Hyuk RYU (KOSHA, Korea)

## TC4-1

### A Study on Electrical Shock and Ignition Hazards by High-Radio Frequency in Korea

Sang Won CHOI, Hyung Soo LEE : Korea Occupational Safety and Health Agency, Korea

## TC4-2

### Study of Determining Customer Connected at Transformer in Low Voltage System

Jae Ick YOO : Graduate School of Energy & Environment, Seoul National University of Science and Technology, Korea  
Jae Hee JOUNG : Department of Safety Engineering, Seoul National University of Science and Technology, Korea  
Jong Soon LEE : Sejong Electric Power 380-6, Korea  
You Sung KIM, Hang Youl KIM : Samsung Loss Control Center, Korea

## TC4-3

### Ground Resistance Measurement Error and its Compensation Method Using the Fall-of-potential Method

Dong Woo KIM, Hyoung Jun GIL, Dong Ook KIM, Ki Yeon LEE,  
Hyun Wook MOON, Hyang Kon KIM : Electrical Safety Research Institute, a subsidiary of Korea Electrical Safety Corporation, Korea

## TC4-4

### Labview-based Monitoring Program for Analysis of Series Arc Signals on Electric Wire

Jong Young PARK, Sung Chul KIM, Doo Hyun KIM : Department of Safety Engineering, Chungbuk National University, Korea  
Boo Hyung RYU : Department of Safety Envir. System Engineering, Dongguk Univ., Korea

## TC4-5

### A Case Study on Floating Roof Tank Fire by Lightning Strikes

Hyung Soo LEE, Chang Wan RYU, Gyung Sung LEE, Joo Gu KIM,  
Dae Sik IM, Chang Gyu LEE : Korea Occupational Safety and Health Agency, Korea

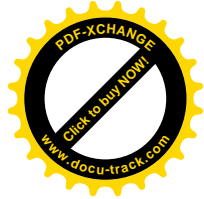
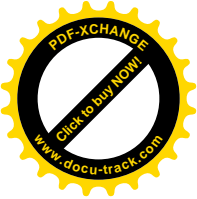

## Technical Session Friday, October 22

Special Lectures (Grand ballroom A, 1st Floor)  
Friday, October 22, 9:00 ~ 10:40

Chair: Keith SCOTT

### FG1-1

Understanding the Occupational Injury statistics of Korea  
Seong Kyu KANG, Director General, OSHRI-KOSHA, Korea

### FG1-2

Occupational Injury Prevention Research in the US:  
Strategic Goals, Activities and Impacts  
Hongwei HSIAO, Chief, Protective Technology Branch, NIOSH

### FG1-3

Introduction of Safety Research Institutes in Japan and  
Development of the International Cooperation System  
Takehiro MATSUNAGA, Secretary, Asia Pacific Association of Safety  
Engineering Societies (APASES), Researcher of National Institute of  
Advanced Industrial Science and Technology, Japan

### FG1-4

Regulation by Directives and Performance Based  
Regulation - Selection and Harmonization  
Doo Yong PARK, Professor, Hansung University, Korea

### FG1-5

Re-launch of Scientific Committee on Accident Prevention,  
Re-union of Health AND Safety - A Case Study  
Su Wang, Board of Directors, IIRSM/ Secretary, ICOH-SCAP

## Poster Session

Poster Exhibition (Grand Ballroom B, 1st Floor):  
Wednesday, October 20, 09:00 ~ 18:00  
Thursday, October 21, 09:00 ~ 18:00  
Friday, October 22, 09:00 ~ 12:00  
Meeting with Authors:  
Wednesday, October 20, 17:40 ~ 18:10

### Accident Prevention Policies and Safety Culture

#### P1-1

A Study on the Legal Aspects of the Transportation of  
Dangerous Goods by Railroad in Korea  
Dong Woo SONG, Su Kyung LEE : Department of Safety Engineering,  
Seoul National University of Technology, Korea  
Don Bum CHOI : KRRI, Korea Railroad Research Institute, Korea

#### P1-2

Our Vision for Accident Reduction  
Qatami Mohd Almaraisi, Abdullah Saad Alhuwaihi, Ali Hassan Alafoom  
: Electricity & Water Authority, Industrial Security & Safety Directorate,  
Kingdom of Bahrain

#### P1-3

Needlestick and Sharps Injuries among Chinese Nurses:  
The Role of Hospital Safety Climate in Accident Prevention  
Derek R. SMITH : School of Health Sciences, Faculty of Health,  
University of Newcastle, Australia  
Isabella ZHAO : School of Nursing & Midwifery, Faculty of Health,

University of Queensland, Australia  
Lina WANG ; Longkou Hospital, China

### Risk Assessment and Management

#### P2-1

Comparison and Analysis of the Legal Approach to Pre-  
vention of Vibration Risk in Europe and North America  
Patrick NDJOM : Ready To Be, France

#### P2-2

A Revised Study for Risk Assessment Models of Railway  
Casualty Accidents  
Chan Woo PARK : Korea Railroad Research Institute, Korea  
Jong Bae WANG, Don Bum CHOI, Sang Log KWAK : Korea Railroad  
Research Institute, Korea

#### P2-3

Development of Accident Scenarios for the Risk Assess-  
ment in Railway System: Focused on the Train Collision  
Don Bum CHOI, Jong Bae WANG, Chan Woo PARK : Railroad Safety  
Technology R&D Corps., KRRI, Korea

#### P2-4

Optimal Safe Layout Standard of DME Filling Stations  
using a Modified Individual Risk  
Young Hun KIM, Won SO, En Sup YOON : School of Chemical &  
Biological Engineering, Seoul Nation University, Korea

#### P2-5

Risk Assessment Model for Decommissioning Safety of  
Nuclear Research Facilities using Risk Matrix and Fuzzy  
Logic  
Kwan Seong JEONG, Kune Woo LEE : Korea Atomic Energy Research  
Institute, Korea  
Hyeon Kyo LIM : Department of Safety Engineering, Chungbuk  
National University, Korea

#### P2-6

Field Application of Risk Based Inspection  
Chang Sub SHIN, Sung Tae KIM, Ho Jun PARK : Department of Safety  
Engineering, Chungbuk National University, Korea

#### P2-7

Reactor Coolant System Depressurization using Dedicated  
Valves for Severe Accidents  
Bag Soon CHUNG : Author Korea Electric Power Corporation Research  
Institute, Korea

#### P2-8

Study on Real Time 3D Evacuate Simulation for Minimize  
of Casualties  
Dong Ho RIE : Safety Engineering, University of Incheon, Korea  
Se Ho RO : Department of Safety Engineering, University of Incheon,  
Korea  
Sung Wook YOON : GS Engineering & Construction, Korea

#### P2-9

The Safety Designs Proposed from the PSA Insights  
Hae Cheol OH : Nuclear Power Lab, KEPRI, Korea

### Accident Prevention Involving Machineries

#### P3-1

Evaluation of P-T Limit Curve for Reactor Beltline Region  
According to Reference Stress Intensity Factor  
Sang Yun PARK, Jong Wook KIM, Tae Wan KIM : SMART  
Development Dept., KAERI, Korea



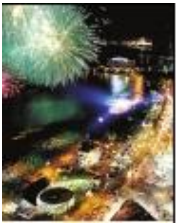
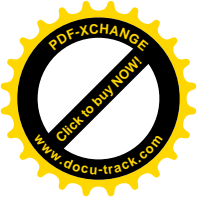

**P3-2**

**A Study of Risk Reduction Strategy for Roll Box Pallets**

Shoken SHIMIZU, Akihiro OHNISHI, Shigeo UMEZAKI : Institute of Occupational Safety and Health, Japan  
Toyoji CHIDA, Tetsuhiro WARITA : GOP Corporation, Japan  
Tatsuya NARITA : Kogakuin University, Japan

**Accident Prevention Involving Electricity**

**P4-1**

**An Analysis of Harmonics Simulation of Grid-Connected Photovoltaic Generation System**

Sang Min LEE, Jae Hee JUNG : Department of Safety Engineering, Seoul National UNIVERSITY of Technology, Korea  
Kang Wan LEE : DAEHWA Engineering & Consultants Co., Ltd, Korea

**P4-2**

**Electrical Properties Analysis of Outdoor LED Road and Street Lighting according to the DC Leakage Current**

Hyang Kon KIM, Hyoung Jun GIL, Dong Ook KIM, Dong Woo KIM, Ki Yeon LEE, Hyun Wook MOON : Electrical Safety Research Institute, Korea Electrical Safety Corporation, Korea  
Hyo Sang CHOI : Electrical Engineering, Chosun University, Gwangju Metropolitan City, Korea

**P4-3**

**Analysis on Types and Characteristics of Electric Shock Accidents In 2009**

Seokwon LEE, Hyung Seok KIM : Occupational Safety & Health Research Institute, Korea

**P4-4**

**Safety Management of Auger Crane Extenders to Ensure Efficient Construction of Distribution Lines**

Chung Seog CHOI : Department of Fire Safety Engineering, Jeonju University, Korea  
Jeom Sik KIM : Daewon Electric Corp., Korea

**P4-5**

**Efficient Safety Management and Finding Causes for Faults in 22.kV, 3-Phase Mold Transformers**

Chung Seog CHOI : Department of Fire Safety Engineering, Jeonju University, Korea

**Fire and Explosion Accident Prevention**

**P5-1**

**Development of Safety Education Program for Simulated Moving Bed (SMB) Process**

Hwe Eung KWON, Young Hee LEE, Jae Duek PARK, Il MOON : Department of Chemical & Biomolecular Engineering, Yonsei University, Korea  
Jin Suk LEE : Base Chemicals Research Team, Samsung Total, Korea

**P5-2**

**Analysis of Thermal Radiation with Steam in Flare Stack**

Heon Seok LEE, Jae Wook KO : Department of Chemical Engineering, Korea  
Dong Il SIN : Department of Chemical Engineering, Myongji University, Korea

**P5-3**

**Research of the Efficiency Improvement According to the Temperature of Foam Concentrate for Prevent the Spread of Fire**

Ha Young KIM, In Ku LEE, Sung Soo KIM : University of Incheon graduate school, Korea  
Dong Ho RIE : University of Incheon, Korea

**P5-4**

**The Measurement and Estimation of the Flash Points for the Acetic Acid+Propionic acid System by Tag-Open Cup Tester**

Dong Myeong HA : Department of Occupational Health and Safety Engineering, Semyung University, Korea  
Sung Jin LEE, Cheol MOON : Department of Clinical Laboratory Science, Semyung University, Korea

**P5-5**

**A Research for Fire-Safety Management of Fire-Resistive Coatings by using N-IR**

Nam Wook CHO, Hyun Joon SHIN : Korea Institute of Construction Technology, Korea  
Dong Ho RIE : University of Incheon, Korea

**P5-6**

**Comparison of Combustion Characteristics of Quercus Spp. by Species**

Hae Rim KIM : Professional Graduate School of Disaster Prevention, Kangwon National University, Korea  
Young Ju PARK : Chemical Engineering Research Center, Kangwon National University, Korea  
Me Jung HWANG, Hae Pyeong LEE : Dept. of Fire & Emergency Management, Kangwon National University, Korea

**P5-7**

**Analysis of Carbon Emissions from Combustion of Conifers**

Young Ju PARK : Chemical Engineering Research Center, Kangwon National University, Korea  
Hae Rim KIM : Professional Graduate School of Disaster Prevention, Kangwon National University, Korea  
Me Jung HWANG, Hae Pyeong LEE : Dept. of Fire & Emergency Management, Kangwon National University, Korea

**P5-8**

**Risk Analysis of Car Fire through Combustion Characteristics**

Hae Pyeong LEE, Me Jung HWANG : Dept. of Fire & Emergency Management, Kangwon National University, Korea  
Seung Chul LEE : Dept. of Fire & Disaster Prevention Engineering, Kangwon National University, Korea  
Hae Rim KIM : Professional Graduate School of Disaster Prevention, Kangwon National University, Korea  
Young Ju PARK : Chemical Engineering Research Center, Kangwon National University, Korea

**P5-9**

**Application of Super Computer for the Study of Fire Driven Flow in the Deeply Underground Subway Station**

Yong Jun JANG, Jin Ho KIM : Korea Railroad Research Institute, Korea

**P5-10**

**Analysis of Fire Patterns occurred in Korea using the Statistical Methods**

Kyong Ae MOON : Dept. of Oriental Medicine and Environment, Hanzhong University, Korea  
Hae Pyeong LEE, Me Jung HWANG : Dept. of Fire & Emergency Management, Kangwon National University, Korea  
Seung Chul LEE : Dept. of Fire & Disaster Prevention Engineering, Kangwon National University, Korea  
Hae Rim KIM : Professional Graduate School of Disaster Prevention, Kangwon National University, Korea  
Young Ju PARK : Chemical Engineering Research Center, Kangwon National University, Korea  
Hyo Beom KIM : Fire Investigation & Inspection Team, National Emergency Management Agency, Korea

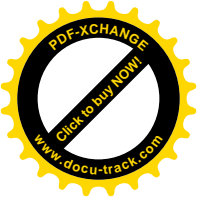

POSTER

## Construction Accident Prevention

**P6-1**

### A Study on the Fire Safety Plan for High-rise Building Construction

Eun Gu HAM, Myeong Gu LEE, Myeong Jin JEONG : University, Department of Environmental Health and Safety, Korea

**P6-2**

### Comparison on the Risk Index between KOSHA Statistics and AHP(Analytical Hierarchy Process) in the Work of Remodeling Construction

Hyung Seok KIM, Kyoung Hun HAN : Occupational Safety and Health Research Institute, KOSHA, Korea

## Traffic Accident Prevention

**P7-1**

### Pedestrian accident case in the parking lot of an apartment

Young Nae LEE, Sung Ji PARK, Seok Hyun YOON, Young Su GONG, Jae Mo GOH : Physical Engineering Div., Western District Office, National Forensic Service(NFS) , Korea

**P7-2**

### Research on Domestic Introduction Plan for Flagger System through Analysis the Accident Injury Severity on a Field of Construction Work

Ji Yeon HONG, Soo Beom LEE : Department of Transportation Engineering, University of Seoul, Korea

**P7-3**

### Tracing Stop Point for Safety of Passenger through Multi brake Modeling in the ATO Train

Kyoung Bok LEE, Heui Seon LEE : R&D Center, Daejeon Rapid Transit Corporation, Korea  
Hi Sung LEE : Dept. of Rolling stock system, Seoul National University of Technology, Korea  
Dong Soo KIM : Director, Daejeon Rapid Transit Corporation, Korea

**P7-4**

### Motorcycle Crash Inpatients' Health Service Utilization and Effect Factors in Taiwan, 2008

I Chen CHENG, Wu Chien CHIEN : School of Public Health, National Defense Medical Center, Taiwan  
Chi Hsiang CHUNG : Graduate Institute of Life Sciences, National Defense Medical University, Taiwan  
Lu PAI : Institute of Injury Prevention & Control, Taipei Medical University, Taiwan

**P7-5**

### TMR Application of Train Control System For High Reliability

Seung Kwon SHIN, Hyun Jung CHO, Jong Kyu HWAN: Korea Railroad Research Institute, Korea  
Yong Gee CHO : LS Industrial Systems, Korea

**P7-6**

### Accident Protection Equipment for Railway Platform using novel Laser Radar Sensory system

Yoi Ho KIM, Tae Kuk KO : Dept. of Electrical & Electronic Eng., College of Eng., Yonsei Univ., Korea  
Jong Gyu HWANG, Hyun Jeong JO : Train Control & Telecommunication Research Division, Korea Railroad Research Institute, Korea  
Kwon Hee CHOI : Railway Technology Co., Ltd., Song Su TAK, Sang Yong JUNG : Korea Gas Safety Corporation, Korea

**P7-7**

### Formal Specification & Verification Process by using Z for Safety Improvement of Railway Signaling System

Hyun Jeong JO, Jong Gyu HWANG, Yong Ki YOON : Train Control & Communication Research Division, Korea Railroad Research institute(KRRI), Korea

## Ergonomics and Systems Safety

**P8-1**

### Ergonomic Comparison of Two Different Methods for Going Upstairs

Dong Gyun KIM, Hyeon Kyo LIM : Dept. of Safety Eng., Chungbuk National University, Korea

**P8-2**

### Exposure to Ergonomic Risk Factors in Korean Workers

Jung Sun PARK, Hyun Ho KIM, Chan Young YOO, Jeung Ho KIM : Occupational Health Department, KOSHA, Korea

**P8-3**

### BNZ Accident Prevention Programmes Case Study

Eta LILIC : Bank of New Zealand Health & Safety and Wellness Manager, New Zealand

## Occupational Accident Analysis and Statistics

**P9-1**

### Structural Effect of Aging of Workforce on the Rate of Occupational Injuries and Illnesses in Korea

Young Sun KIM, Kyung Yong RHEE : Occupational Safety and Health Research Institute, Occupational Safety and Health Agency , Korea

**P9-2**

### Epidemiology of Injury Hospitalized Elderly Dementia Patients in Taiwan, 2008

Yu Hua LU, Sen Yeong KAO, Wu Chien CHIEN : School of Public Health, National Defense Medical Center, Taiwan  
Chi Hsiang CHUNG : Graduate Institute of Life Sciences, National Defense Medical Center, Taiwan

**P9-3**

### Characteristics of Injured Inpatients among Adolescent Aged 15-19 in Taiwan, 2008

Si Wen YU, Yao Wei HUANG : School of Public Health, National Defense Medical Center, Taiwan  
Chi Hsiang CHUNG : Graduate Institute of Life Sciences, National Defense Medical Center, Taiwan  
Wu Chien CHIEN : School of Public Health, National Defense Medical Center, Taiwan

## Agricultural Safety and Health

**P10-1**

### Characteristics of the Hand Shape of Korean Farmers

Do Hi KIM, Kyung Suk LEE , Hye Seon CHAE, Hyo Cher KIM : Rural Development Administration, Korea

## Safety and Health Management System

**P11-1**

### Methodology to Implement of Efficient and Effective Safety and Health Management System in Organization

Hun Hee LEE : DNV Business Assurance Korea, Korea

**P11-2**

### Setting a Course on Safety

Erwin B. DACULAN : University of San Carlos, EE/ECE Department, Philippines

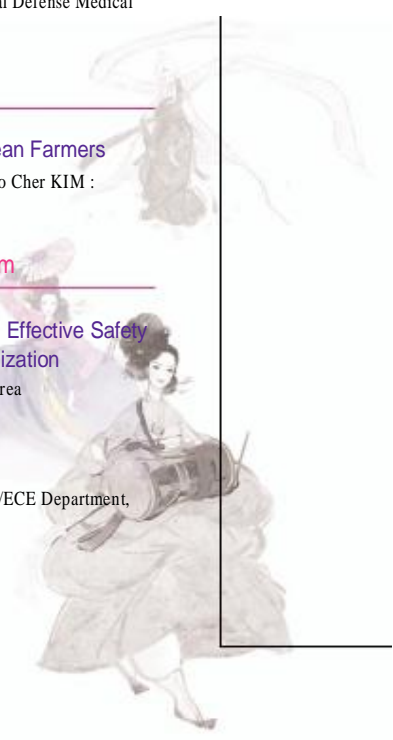

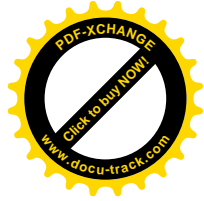

October 20 ~ 22, 2010  
The Westin Chosun Hotel, Busan, Korea

18



## Technical visit

- 
- 
- 

Tour Suggestion	Tour Name	Worksite
Technical Visit 1	Shipbuilding	Hyundai Heavy Industries
Technical Visit 2	Car Manufacturing	Hyundai Motor Company
Technical Visit 3	Nuclear Power Generation	KORI Nuclear Power Plants
Technical Visit 4	Energy	SK Energy



## Busan City Tour

- 
- 
- 

Tour Name	Tour Spots
Busan City Tour	Busan Museum, Haedongyonggungsa Temple, UN Memorial Cemetery in Korea



The 1<sup>st</sup> International Conference on  
Accident Prevention

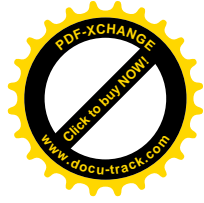
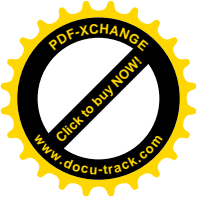

# 1st Floor GBR

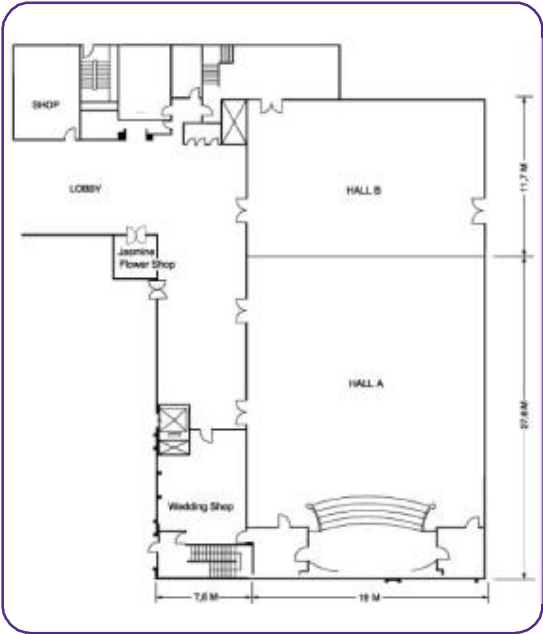

Grand Ballroom A	Grand Ballroom B
Opening Ceremony Keynote Speeches Welcome Reception Gala Dinner Special Lectures Closing Ceremony	Poster Session

FLOOR

# 2nd Floor Rose/Lilac/Tulip/Cosmos

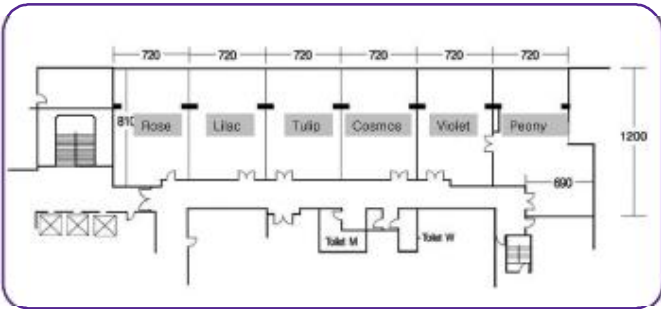

Rose+Lilac   Tulip+Cosmos	
Session1	Session2
1, 4, 7, 10, 13, 2	5, 8, 10, 11, 14
Violet	Peony
Session3	Secretariat office
3, 6, 9, 12, 15	

# 2nd Floor Orchid

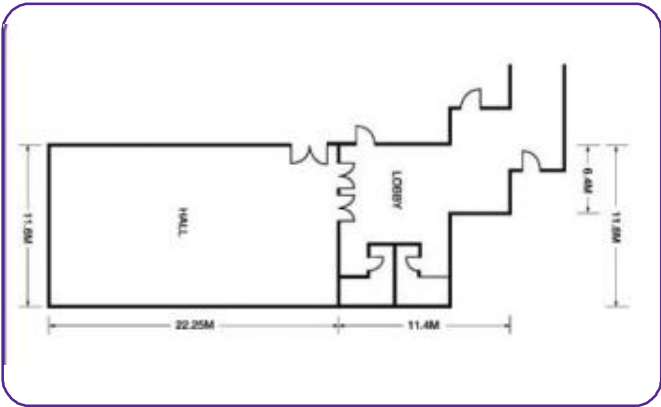

Orchid Luncheon
Entrance Registration



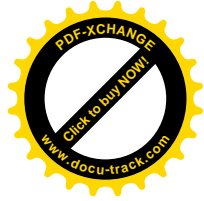

## Location Map

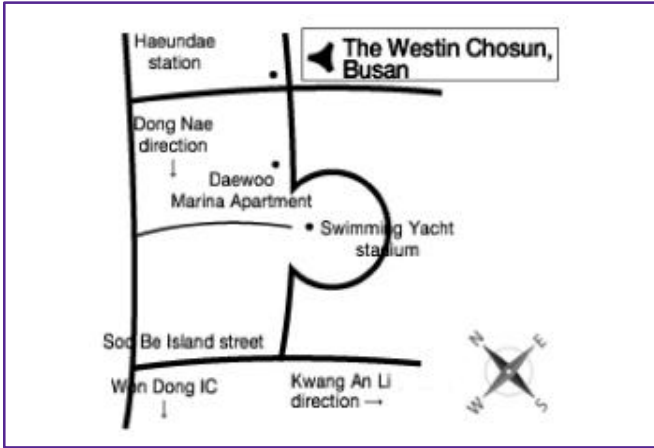

October 20 ~ 22, 2010  
The Westin Chosun Hotel, Busan, Korea

20

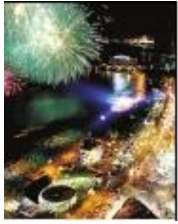

## Transportation Information

- Line 2 : Dong Baek Station
- Line 1 : Transfer to line 2 at So Myon Station

- General City Bus : 5, 31, 36, 38, 39, 40, 63, 100, 115-1, 139, 141, 181
- Express Bus : 1003 (Dong Baek Island or Un-cheon Bus stops)

## Transportation to Kimhae International Airport

Airport -The Westin Chosun Busan : 60 min(Approximately).

	First Bus	Last Bus	Fee
Airport - The Westin Chosun Busan	07:15	22:00	6,000Won
The Westin Chosun Busan - Airport	05:30	20:15	6,000Won

- Regular : 25,000Won (Toll Fee will be added)
- Deluxe : 40,000Won (Toll Fee will be added)  
(Toll Fee : 1,200Won)

Route	Vehicles Type	Fee (Pick-up / Sending)
Airport - The Westin Chosun Busan	Equus	65,000Won / 60,000Won
	Equus Limousine	75,000Won / 70,000Won
	Bus / 15 persons	80,000Won
	Bus / 35 persons	200,000Won

■Time : 06:00~22:00    ■Information : 82(Country Code) - 51(Area Code) - 749 - 7431

The 1<sup>st</sup> International Conference on  
Accident Prevention

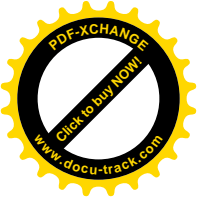

## Sponsors

International Network of Safety and Health Practitioner Organization  
KORI Nuclear Power Site  
Busan Metropolitan City  
Korea tourism Organization  
Busan Convention and Visitors Bureau  
Maeil Business Newspaper  
Safety News  
Electrical Safety Research Institute, Korea Electrical Safety Corporation  
Institute of Gas Safety R&D, Korea Gas Safety Corporation  
Korea Construction Safety Technology Association  
Korea Industrial Safety Association  
Korea Safety Equipment Association  
Korean Institute of Chemical Engineers  
General Institute Association of Korea  
Samsung Global Environment Research Center  
Hyundai Heavy Industries  
Hyundai Motor Company  
Hyundai Development Company  
Hyundai Engineering & Construction  
GS Engineering & Construction GS  
Samsung Construction & Technology Corporation  
Samsung Electronics  
S-OIL  
SK Energy SK  
SK Engineering & Construction SK  
Doosan Heavy Industries & Construction

SPONSOR

## Secretaries of the ICAP 2010

### Secretariat Office

Peony Room 2F, The Westin Chosun Hotel Busan  
Operating Hours : 08:00 ~ 22:00 hr

---

### Korea Occupational Safety & Health Agency

International Cooperation Center  
Secretariat for the Seoul Declaration on Safety and Health at Work  
EMAIL : overseas@kosha.net  
34-4 Gusan-dong Bupyeong-gu, Incheon, 403-711, Korea  
Tel : +82-32-5100-742, FAX : +82-32-502-7199

### The Korean Society of Safety

EMAIL : Kosos@kosos.or.kr  
635-4 Yeoksam-dong, Kangnam-gu, Seoul, 135-703, Korea  
Tel : +82-2-552-9331, FAX : +82-2-552-9332



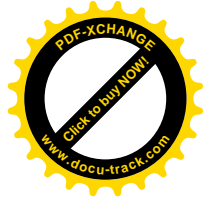
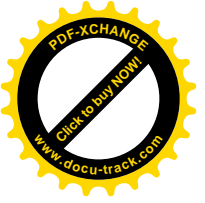

# ICAP 2010

## The 1<sup>st</sup> International Conference on Accident Prevention

October 20 ~ 22, 2010  
Westin Chosun Hotel, Busan, Korea

<http://www.icapkorea.org>

